

northerntrack

Construction Demolition & Recycling Attachments



NTSG Series - Selector Grapple

northerntrack

SELECTOR GRAPPLES

The Selector Grapple can be used to demolish, sort, load, reduce, screen or excavate a wide range of materials. The grapples are equipped with a 360 degree hydraulic rotation which allows the operator increased control and enables precise movement and positioning of the handled material. Selector Grapples are also highly suited to many "stripping" operations prior to major demolition work and permit the separation and sorting of all the differing materials. This in turn presents far greater opportunities for reclamation and recycling along with increased safety and savings in time and cost. In the current climate of increasing environmental concerns and recent legislation affecting all material disposal the selector grapple will quickly prove to be an indispensable partner.

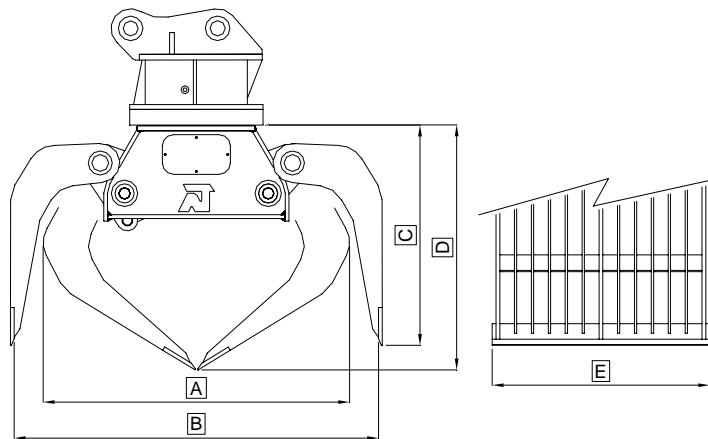

MODEL		NTSG 5	NTSG 8	NTSG10	NTSG15	NTSG20	NTSG30
A	[mm]	820	880	1400	1500	1600	1750
B	[mm]	1100	1375	1730	1850	2000	2270
C	[mm]	595	650	1000	1100	1165	1250
D	[mm]	660	820	1050	1150	1290	1400
E	[mm]	600	600	900	1000	1150	1300
Opening Pressure	[bar]	300	300	300	300	300	300
Flow	[l/min]	30-40	30-40	50-60	50-60	100-120	100-120
Rotation Pressure	[bar]	130	130	130	130	130	130
Flow	[l/min]	10	10	15	15	20	20
Capacity	[m ³]	0.2	0.4	0.6	0.8	1.1	1.3
Weight	[kg]	340	460	1100	1500	1750	2150
Machine Weight	[tonne]	3-5	6-10	11-16	17-22	23-32	33-40

Specifications subject to modification at manufacturers discretion. All weights/sizes approximate. E&OE



Northerntrack Ltd
 Climax Works, Garnet Road
 Leeds LS11 5JD
 Tel: +44 (0)113-2762-300
 Fax: +44 (0)113-2762-400
 sales@northerntrack.co.uk
 www.northerntrack.co.uk