



PM Series Handling Grapple



UK Dealer Sales & Service

Northerntrack Ltd
Climax Works
Garnet Road
Leeds LS11 5JD

Tel. +44 (0)113 2762 300
Fax +44 (0)113 2762 400
www.northerntrack.co.uk
info@northerntrack.co.uk

PM Series

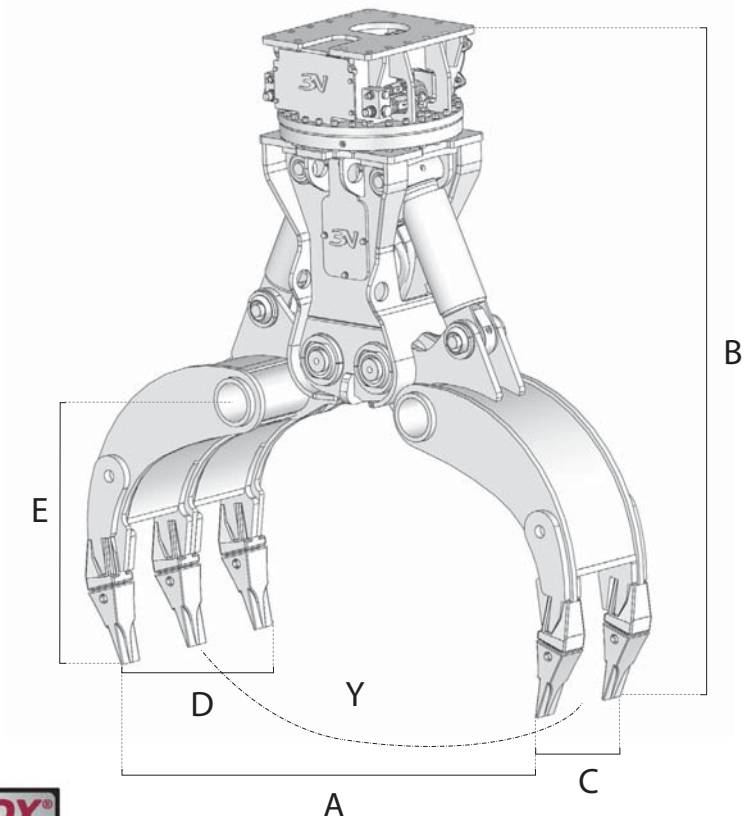

HARDOX
WEAR PLATE

HARDOX
IN MY BODY

		PM 10	PM 15	PM 20	PM 30
(1)	t.	10 : 15	15 : 20	20 : 30	30 : 40
	kg.	800	1250	1850	3200
A	mm.	920	1570	1750	2180
B	mm.	1870	2020	2200	2800
C	mm.	360	400	530	630
D	mm.	550	710	810	980
E	mm.	800	800	850	1100
Y	t.	4	6	10	15
Cap. SAE	m ³	0,4	0,6	0,9	1
	bar	310	310	310	310
	l/min.	100 / 120	100 / 200	180 / 250	200 / 300
max	bar	140	140	140	140
max	l/min.	10	10	10	10

(1) Accoppiamento escavatore-attrezzatura consigliato (1) Excavator-equipment recommended combination (1) Couplage pelle-équipement recommandé
(1) Acoplamiento excavadora-implemento aconsejado (1) /Empfohlene Kombination von Bagger und Ausrüstung