



CS Series Steel Shears



UK Dealer Sales & Service

Northerntrack Ltd
Climax Works
Garnet Road
Leeds LS11 5JD

Tel. +44 (0)113 2762 300
Fax +44 (0)113 2762 400
www.northerntrack.co.uk
info@northerntrack.co.uk

CS Series

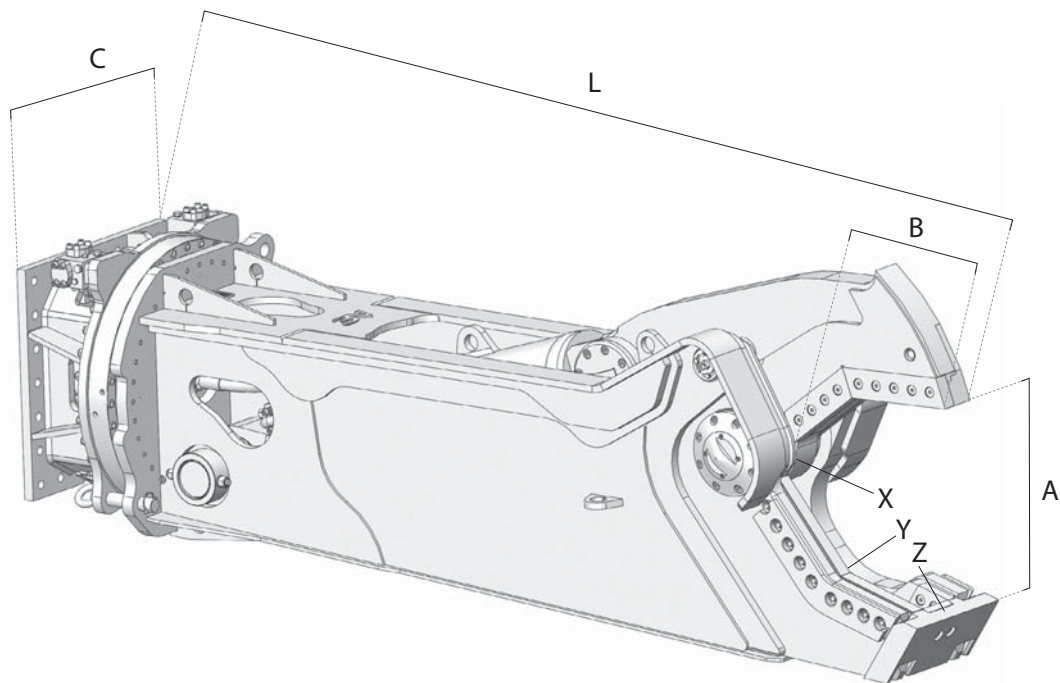

HARDOX
WEAR PLATE



HARDOX
IN MY BODY

		CS 05R	CS 07R	CS 12RS	CS 20RS	CS 25RS	CS 30RS	CS 40RS	CS 55RS	CS 70RS	CS 90RS	CS 200RS
(1)	t.	2,5 : 4	4 : 7	7 : 10	10 : 16	16 : 20	20 : 25	25 : 30	30 : 40	45 : 55	70 : 90	140 : 190
(1)	t.	5 : 8	8 : 12	12 : 18	18 : 23	23 : 30	30 : 38	40 : 50	55 : 70	75 : 100	120 : 150	200 : 280
	kg.	450	750	1180	1650	2350	2800	3900	5650	7180	9250	19160
A	mm.	340	405	475	535	570	615	680	780	845	920	1180
B	mm.	320	355	385	445	505	545	600	690	710	780	1130
C	mm.	460	460	570	715	715	715	865	1000	1100	1200	1750
L	mm.	1725	2050	2300	2660	2950	3110	3420	3905	4190	4400	5580
X	t.	125	210	225	250	420	550	600	700	815	1075	1540
Y	t.	50	90	95	110	180	230	270	290	375	480	690
Z	t.	25	50	55	60	100	125	145	160	205	265	350
	bar	250	310	310	310	310	340	340	340	340	340	340
	l/min.	80 / 150	100 / 150	150 / 250	180 / 250	200 / 300	200 / 300	300 / 400	400 / 500	450 / 600	500 / 800	900 / 1200
	bar	120	120	140	140	140	140	140	140	140	140	140
	l/min.	10	10	10	10	10	10	10	30	30	50	50
		/	/	/	/	/	/	/	√	√	√	√

(1) Accoppiamento escavatore-attrezzatura consigliato | Excavator-equipment recommended combination | Couplage pelle-équipement recommandé | Acoplamiento excavadora-implemento aconsejado | Empfohlene Kombination von Bagger und Ausrüstung